

Technical data sheet

Product features



Cooking range induction 4 zones

Model	SAP Code	00013593
--------------	-----------------	----------



- Device type: Electric unit
- Power consumption of the zone 1 [kW]: 5
- Power consumption of the zone 2 [kW]: 5
- Power consumption of the zone 3 [kW]: 5
- Power consumption of the zone 4 [kW]: 5
- Protection of controls: IPX5
- Material: Stainless steel

SAP Code	00013593	Number of zones	4
Net Width [mm]	800	Power consumption of the zone 1 [kW]	5
Net Depth [mm]	800	Power consumption of the zone 2 [kW]	5
Net Height [mm]	422	Power consumption of the zone 3 [kW]	5
Net Weight [kg]	43.00	Power consumption of the zone 4 [kW]	5
Power electric [kW]	20.000	Ceramic glass dimensions [mm x mm]	750 x 770
Loading	400 V / 3N - 50 Hz		

Technical data sheet

Technical drawing



Cooking range induction 4 zones

Model

SAP Code

00013593



Tabella			
Descrizione	A	C	D
PCID-84ET	400 mm	100 cm ²	150 cm ²
PCID-88ET	800 mm	165 cm ²	200 cm ²

A	Data plate		B	Electrical connection	
---	------------	--	---	-----------------------	--

Technical data sheet

Technical parameters

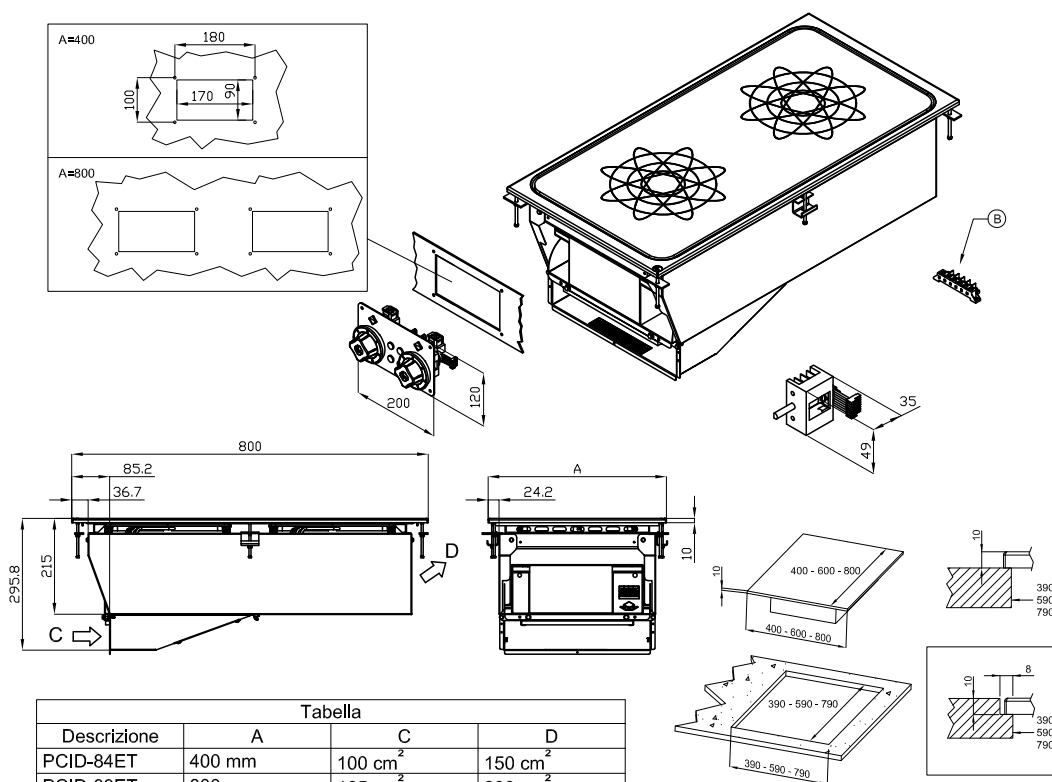

Cooking range induction 4 zones

Model	SAP Code	00013593
--------------	-----------------	----------

1. SAP Code:

00013593

2. Net Width [mm]:

800

3. Net Depth [mm]:

800

4. Net Height [mm]:

422

5. Net Weight [kg]:

43.00

6. Gross Width [mm]:

830

7. Gross depth [mm]:

970

8. Gross Height [mm]:

540

9. Gross Weight [kg]:

50.00

10. Device type:

Electric unit

11. Construction type of device:

Drop-in

12. Power electric [kW]:

20.000

13. Loading:

400 V / 3N - 50 Hz

14. Protection of controls:

IPX5

15. Material:

Stainless steel

16. Worktop type:

Molded - comfortable cleaning maintenance

17. Worktop material:

AISI 304

18. Worktop Thickness [mm]:

2.00

19. Number of zones:

4

20. Power consumption of the zone 1 [kW]:

5

21. Power consumption of the zone 2 [kW]:

5

22. Power consumption of the zone 3 [kW]:

5

23. Power consumption of the zone 4 [kW]:

5

24. Power control type:

knob control

25. Number of power control stages:

6

26. Service accessibility:

From the front by removing the front panel and waste fluid containers

27. Number of burners/hot plates:

4

28. Type of electric cooking zones:

Induction

Technical data sheet

Technical parameters



Cooking range induction 4 zones

Model

SAP Code

00013593

29. Ceramic glass dimensions [mm x mm]:

750 x 770

30. Cross-section of conductors CU [mm²]:

10

– Výkon (kW): 5,7-6,6 (230 V); 9,8-11 (400 V)